	<b>ITTC – Recommended Procedures and Guidelines</b>		<b>7.5-01 -03-04</b> Page 1 of 18
	<b>Benchmark for PIV(2C) and SPIV(3C) setups</b>		Effective Date 2017

## ITTC Quality System Manual

### Recommended Procedures and Guidelines

#### Guideline

### Benchmark for PIV(2C) and SPIV(3C) setups

7.5	Process Control
7.5-01	Test Preparation
7.5-01-03	Instrumentation, Calibration
7.5-01-03-04	Benchmark for PIV(2C) and SPIV(3C) setups

Updated / Edited by	Approved
Resistance Committee of the 28 <sup>th</sup> ITTC	28 <sup>th</sup> ITTC 2017
Date 03/2017	Date 09/2017

	<b>ITTC – Recommended Procedures and Guidelines</b>	<b>7.5-01 -03-04</b> Page 2 of 18	
	<b>Benchmark for PIV(2C) and SPIV(3C) setups</b>	Effective Date 2017	Revision 01

## Table of Contents

<b>1. PURPOSE OF PROCEDURE.....3</b> <b>2. SCOPE.....3</b> <b>3. BENCHMARK OBJECTIVES FOR THE VERIFICATION OF PIV/SPIV SETUP .....3</b> <b>4. PIV BENCHMARK SETUP .....4</b> <b>4.1 2C PIV Setup Benchmark.....4</b> <b>4.2 Stereo PIV Setup Benchmark.....6</b>	<b>4.3 Benchmark test results..... 8</b> <b>5. ORGANIZATION..... 11</b> <b>6. REFERENCES ..... 12</b> <b>APPENDIX A : QUESTIONNAIRE..... 13</b> <b>APPENDIX B BENCHMARK PERFORMANCE INSTRUCTIONS 16</b> <b>APPENDIX C : REPOSITORY ACCESS 18</b>
---	---

	<b>ITTC – Recommended Procedures and Guidelines</b>	<b>7.5–01 -03-04</b> Page 3 of 18	
	<b>Benchmark for PIV(2C) and SPIV(3C) setups</b>	Effective Date 2017	Revision 01

## Benchmark testing for PIV (2 component) and Stereo PIV (3 component) setups

### 1. PURPOSE OF PROCEDURE

The purpose of this procedure is to continue the establishment of a benchmarking test for PIV/SPIV setups that was initially proposed in the 26<sup>th</sup> and 27<sup>th</sup> ITTC. Specifically, this procedure has the following objectives:

- To define a set of criteria that a benchmark test must adhere to;
- To propose two test cases: one for 2C PIV and one for Stereo-PIV;
- To provide clear instructions for performing the benchmark test including details about the model to be used, the measurement conditions and the measurement parameters;
- To provide details about the organization of the benchmark program, including information about the conditions to access to the repository and to store the data.

### 2. SCOPE

One area that is critical towards facilitating the adoption of detailed flow measurements is the availability of benchmark data for the purpose of verifying the quality of the measurement setup. The primary purpose of using these benchmark cases is to ensure that the measurement system and the configuration of the cameras and light sheet meet specifications and also to give an indication to the new user of the PIV technique of how successful the measurement technique has been implemented. Further, the availability of benchmark data provides the new user with the ability to evaluate and compare their measurement setup with other established institutions.

Thus the situations in which a benchmark test may be advantageous to an institution/organization are:

- An organization may be acquiring a PIV system and would like to evaluate it on a simple known flow.
- An organization has acquired a PIV system and is in the process of learning the system or need to train test personnel in using the system.
- An organization needs to evaluate the performance of an existing PIV system to ensure that it meets industry standard and customer performance criteria.

### 3. BENCHMARK OBJECTIVES FOR THE VERIFICATION OF PIV/SPIV SETUP

The main objectives of a benchmark test are:

- Simple and cheap experimental setup to be used during any test campaign in the facility.
- Detailed specifications to assure a high repeatability test among the partners.
- Minimize the time for the test setup would incorporate into a scheduled measurement program. Test setup would require approximately an extra 2 hour.
- Measurements performed in 1 or 2 repetitions.
- Test case representative of typical PIV setup and the issues associated with these setups.
- The possibility to exchange and compare images and velocity data.

 INTERNATIONAL TOWING TANK CONFERENCE	<b>ITTC – Recommended Procedures and Guidelines</b>	<b>7.5–01 –03–04</b> Page 4 of 18	
	<b>Benchmark for PIV(2C) and SPIV(3C) setups</b>	Effective Date 2017	Revision 01

Recognizing again that potential applications for PIV are wide ranging and would concern practitioners of various levels of knowledge and experience, the committee is proposing two distinct benchmark cases. The first benchmark case utilizes a two-component PIV system on a simple 2D geometry. The second benchmark test uses an SPIV system on a more complex 3D flow field that has been established by the European Network of Excellence Hydro Testing Alliance (HTA).

One of the key aspects of establishing a benchmark test is the ability to disseminate the data from various institutions and organizations from the tests. This implies that all relevant aspects of the test must be made available to any member organization partaking in the benchmark tests. Of specific interest are the PIV images obtained during the tests, as well as processed results, such that participants can not only compare their own images, but also their PIV processing algorithms on other image sets. Thus, a repository for the benchmark data has to be established.

Due to the inherent differences between a 2C and an SPIV (3C) setup, two different benchmark tests are proposed.

#### 4. PIV BENCHMARK SETUP

##### 4.1 2C PIV Setup Benchmark

A simple 2C benchmark case, based on the experiment performed by Hudy and Naguib (2003), is proposed for the purpose of the verification of the setup of 2C PIV systems.

A good benchmark case should include typical flow features found in marine hydrodynamics such as flow separation and vortex generation. At the same time, it should be easy to set up and should not be very sensitive to changes in flow conditions such as small change in Reyn-

olds number or small manufacturing imperfection of the model. For these reasons, a separating-reattaching flow around a splitter plate with a fence is chosen as a candidate.

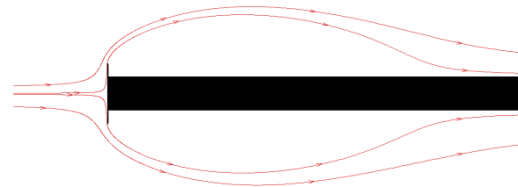

Figure 1 Flow around splitter plate with fence

Figures 1 and 2 illustrate the geometry and the flow, more details are reported in Appendix B. The fence height above the splitter plate ( $h_f$ ) is 10 mm, and the total fence height ( $2H$ ) is 40 mm. In order to assure two-dimensional flow, both ends of the plate and fence should either span the entire width of the test section or be attached to end plates of sufficient size. The influence of flow parameters and model geometry on the flow field was investigated using 2D RANS simulations with the commercial CFD code Fluent. The Reynolds number based on the fence height and the free stream velocity is 8000.

Over the course of the study, various tip geometries were examined, and the results show that the geometry illustrated in Figure 3 to be suitable.

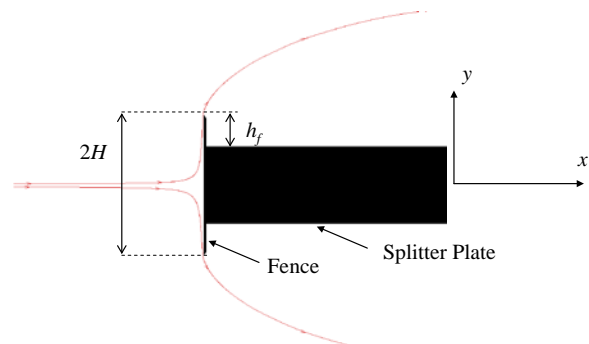



Figure 2 Geometry of the 2D benchmark

 <b>ITTC</b> INTERNATIONAL TOWING TANK CONFERENCE	<b>ITTC – Recommended          Procedures and Guidelines</b>	<b>7.5–01          -03-04</b> Page 5 of 18	
	<b>Benchmark for PIV(2C) and SPIV(3C)          setups</b>	Effective Date 2017	Revision 01

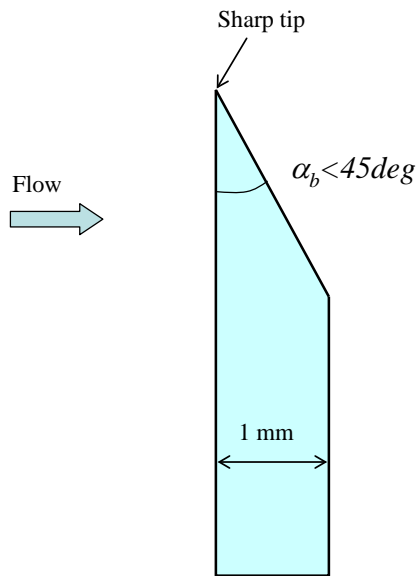

Figure 3 Detailed geometry of the fence

The front face of the fence is kept flat and perpendicular to the flow axis to create a stagnation flow before it detaches from the sharp tip. Results show that if the backside is beveled less than 45 degrees, the flow is not sensitive to small variation in the bevel angle or the fence thickness. Velocity vectors near the fence are shown in Figure 4.

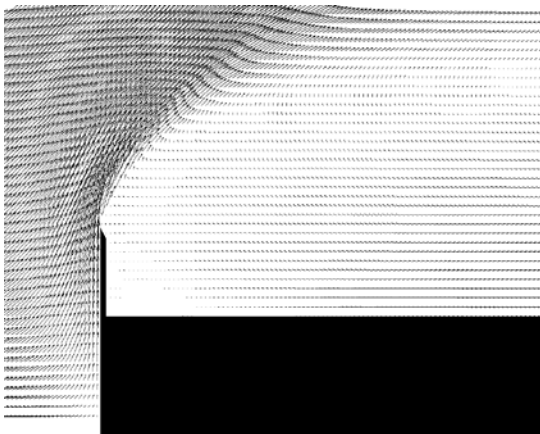

Figure 4 Velocity vectors around the fence

RANS simulations at Reynolds numbers of 16000, 8000 and 4000 were carried out and confirmed that the reattachment location does not change significantly with Reynolds number,

making the flow relatively insensitive to small variation in tunnel speed and water properties.

The influence of the splitter plate length was also investigated. Because of the pressure gradient at the end of the splitter plate, the reattachment location was found to be weakly dependent on the splitter plate length. However, when the splitter plate length is more than 100 times the fence height above the splitter plate ( $h_f$ ), the effect of the splitter plate length was found to be negligible.

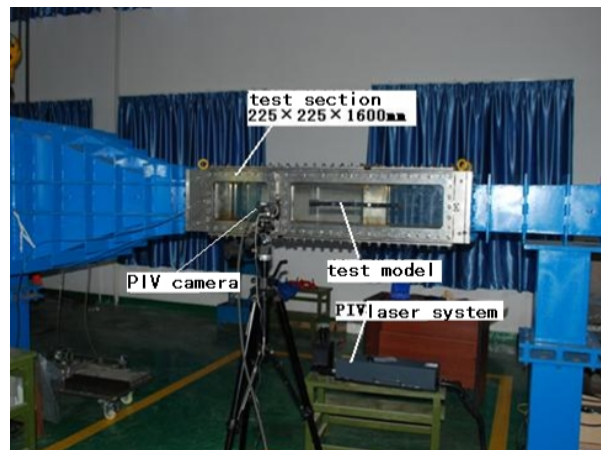

Figure 5: CSSRC multi-function high speed cavitation tunnel with PIV setup.

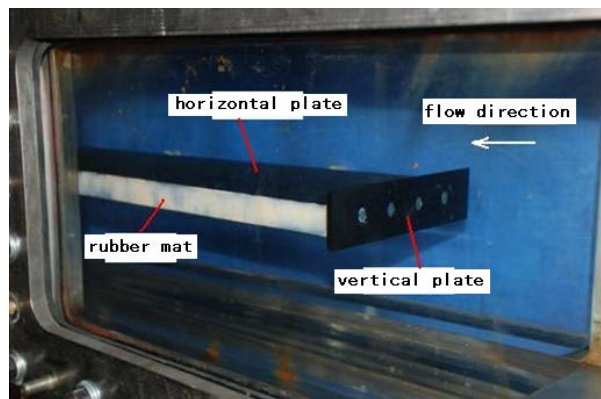



Figure 6: 2D benchmark test model fitted in the CSSRC facility shown in Figure 5.

This preliminary assessment is based on 2D steady RANS. The benchmark case has only been tested by one institution at the time of writ-

	<b>ITTC – Recommended Procedures and Guidelines</b>	<b>7.5–01 –03-04</b> Page 6 of 18	
	<b>Benchmark for PIV(2C) and SPIV(3C) setups</b>	Effective Date 2017	Revision 01

ing of this publication, CSSRC. The measurement was performed in their multi-function high speed cavitation tunnel as shown in Figure 5. The 2D benchmark test model is shown in Figure 6.

A low speed 2D PIV setup was used, with data obtained at a sampling frequency of 2Hz. Appropriate care was taken with the laser power to avoid the over-saturation of the images. The average flow field, evaluated from 75 instantaneous measurements, is shown in Figure 7. It shows that behind the vertical plate there are two main vortex areas, one is a small clockwise vortex, another is a large counter clockwise vortex, and the velocity amplitude in the vortex area is low, but high in the external flow field. A shear layer region is visible between the vortex region and the outer flow field region, which makes the low speed vortex area “packaged” and attached to the horizontal plane.

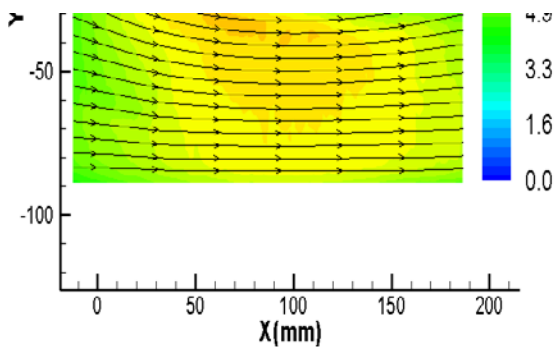

Figure 7: Experimental results from the CSSRC 2D benchmark study.

The 2C benchmark has only been performed at one institution, but participating institutions are invited to begin performing the benchmark tests. To this aim, detailed instructions for performing the benchmark test are reported in Appendix B. Additionally, more detailed computations, possibly with URANS or LES are also needed to help with the benchmark model parameters.

## 4.2 Stereo PIV Setup Benchmark

A surface piercing flat plate operating at incidence is selected as the test case for SPIV benchmarking. This test case was devised by the European Network of Excellence Hydro Testing Alliance (HTA), and many of the HTA members have participated in its assessment. After consultations with the HTA working group, the Detailed Flow Measurement Techniques Committee has decided to recommend the HTA benchmark case as the ITTC benchmark case for SPIV configurations. In addition to the objectives stated earlier, the SPIV case:

- should be representative of the major critical issues of SPIV measurements in towing tanks or circulating water channels, such as high velocity gradients, surface effects, presence of air bubbles and reflections;
- should represent a simple and cheap experimental setup that can be adapted to the multitude of facilities;

Figure 8 shows a representative sketch of the surface piercing flat plate. The plate is a steel rectangular plate measuring 800 mm (L) x 500 mm (W) x 6.35 mm (H). Both leading and trailing edges of the plate have a round edge of 3.175 mm radius. The plate experiences some deformation when operating at incidence. It is therefore important to assure the plate deformation be repeatable in all the benchmarking exercises. In this regard, the benchmark case also specifies the geometry of the anchoring system, which consists of aluminum blocks held together by screws, as detailed in Figure 9.

The flat plate model has been built by INSEAN, and the model was shipped to various HTA members to test at their respective facilities, be it towing tanks, circulating water tunnels, or cavitation tunnels. The choice of facility is not prescribed as it is assumed that unique requirements of each facility may dictate some differences in procedures and test setup. Since

the actual physical model is the same, each organization would be free to approach the test case in its own way, for example reflections can be minimized using special paints, using fluorescent seeding particles or special filters.

Two experimental configurations have been proposed to fit the standard characteristics of towing tanks and circulating water channels, as documented in Table 1. However, due to limitations in facilities, it may be inevitable that the parameters for towing tanks might have to be used in a circulating facility and vice versa.

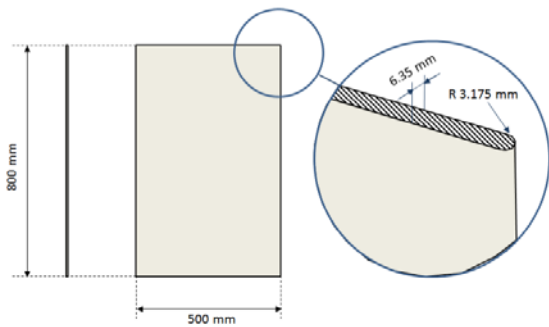

Figure 8 Flat plate geometry

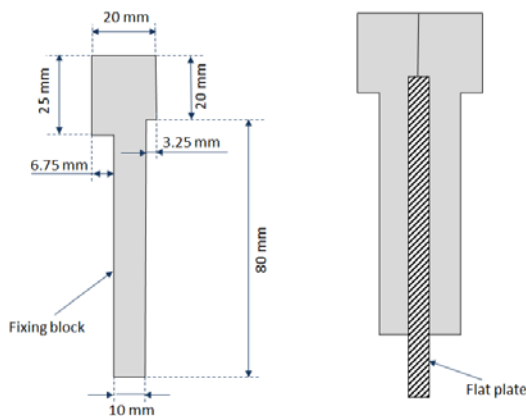

Figure 9 Flat plate fixing blocks

Two cross planes in the near tip region of the flat plate (Figure 10), located 100 mm in front (plane P1) and behind (plane P2) of the trailing edge, have been identified for the benchmarking exercise. Plane P1 would be subject to laser light reflections from the model, while P2 would have no model reflections present, but a very

strong vortical structure. An upstream cross plane far enough from the leading edge also has been considered to survey the undisturbed velocity field. The field of view is rectangular (at least 200 mm high by 300 mm wide) and is situated on the suction side of the incident plate.

	Towing tank	Circulating water channel
Plate dimensions (L x W x H) (mm)	500 x 800 x 6.35	500 x 800 x 6.35
Speed (m/s)	0.4	2
Angle of incidence (deg)	20	5
Tip-free surface distance (mm)	300	300

Table 1 Configurations for towing tank and circulating water tunnel

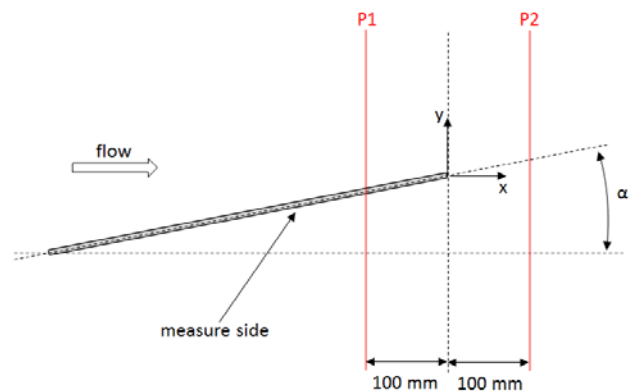

Figure 10 Measurement planes

The dataset should consist of at least 128 instantaneous three dimensional velocity fields. For the sake of maintaining a homogeneous data format among participants, mean velocity fields should be provided according to the following order: X (mm), Y (mm), Z (mm), U (m/s), V (m/s), W (m/s).

The origin of the reference system has been set at the trailing edge of the plate tip, with the X axis aligned to the free-stream direction, the Z axis vertical and the Y axis horizontal and oriented from the low to the high pressure side of the plate.

Instantaneous images from the left and right cameras in tiff or bmp format, instantaneous velocity fields from the left and right camera and after the stereo reconstruction, calibration images, datasheet with the mean velocity fields as previously specified, testing and processing information (e.g., left and right camera arrangement, set up specifics, processing and stereo reconstruction techniques and parameters) are requested to be supplied by each of the participants.

Detailed specifications of the Stereo-PIV benchmark are available in Appendix B. Results from a sample of tests carried out by HTA member facilities has also been presented by Muthanna et al. (2010) and are presented in the next section.

### 4.3 Benchmark test results

The following section presents some results from HTA member facilities that have performed the stereo PIV benchmark tests. The work has been presented by Muthanna et al. (2010) and is summarized here.

The three data sets that are compared here are from

- INSEAN (Italian Ship Model Basin)
- Laboratory for Aero & Hydrodynamics at the Delft University of Technology (TUD)
- Maritime Research Institute Netherlands (MARIN) (cooperation MARIN-SIREHNA)

Among the results discussed here, INSEAN and MARIN performed the benchmark tests in their respective towing tanks, and TUD performed the tests in their circulating water tunnel. INSEAN have used their PIV system developed in collaboration with TSI. MARIN has used a PIV system developed by Dantec Dynamics, and operated by SIREHNA. TUD has used a custom PIV solution using the DAVIS analysis software. Thus, it can be expected that there will

be some differences in the results obtained. The INSEAN configuration was an asymmetrical 3-Component PIV setup as shown in Figure 11. MARIN also used an asymmetric setup in the towing tank as shown in Figure 12. A sketch of the configuration in the water tunnel at Delft is shown in Figure 13.

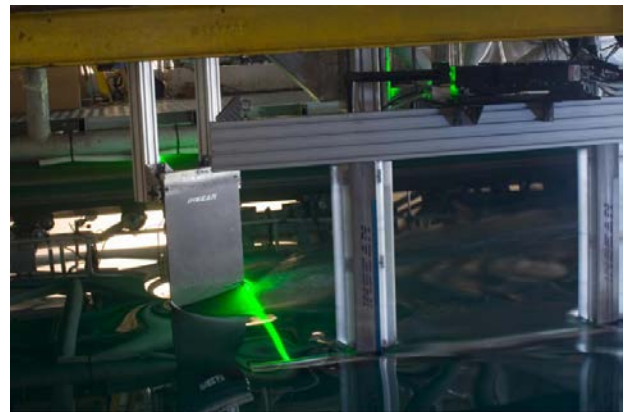

Figure 11: Benchmark model in the INSEAN towing tank.

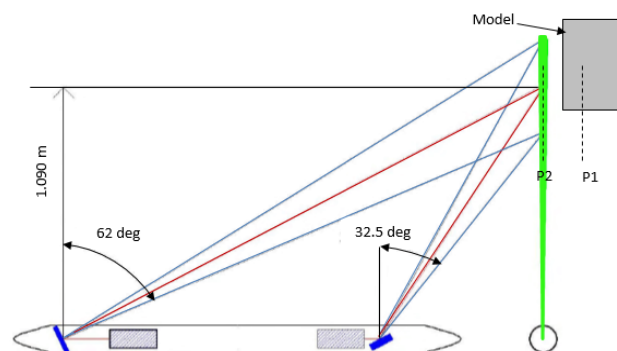

Figure 12: Sketch of MARIN's stereo PIV setup

The velocity data was delivered in ASCII format giving the measurement grid in X, Y, Z, and the three velocity components U, V, and W. The data sets being compared here are the average velocity maps as computed by each individual institution's averaging algorithms. The data is presented on the interpolated grid as specified, and again, the interpolation routines were chosen by each institution.

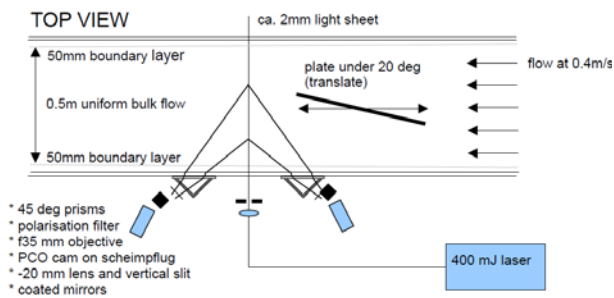

Figure 13: Sketch of TUD's stereo PIV setup in a circulating water tunnel.

Shown in Figures 14, 15, and 16 are the mean velocity contours of the  $U$ ,  $V$ , and  $W$  components respectively for the P1 measurement plane. This plane would be most affected by the presence of the flat plate, due to reflections from the plate surface, and thus impact the overall image quality of the PIV measurement.

The out-of-plane (i.e. streamwise) component of the velocity,  $U$ , is shown in Figure 14. This measurement result is the most sensitive to the setup of the Stereo PIV hardware in terms of making an accurate measurement. While the MARIN data sets show the presence of a large region of velocity deficit near the flat plate, the INSEAN data does not. This same region is visible in the TUD data, but it should be noted that the position of the flat plate in the TUD data set seems to be considerably different from that in the two towing tanks (likely relating to coordinate system definition).

However, when comparing the in-plane velocity measurement,  $V$  (spanwise, or parallel to the free surface, Figure 15), the three data sets are very similar, showing similar values for the measured velocities, as well as the same flow structures with the exception of the INSEAN data, whose results seem to be affected more than the others at this measurement location. However, the general trend of the INSEAN data indicates a similar flow structure as that seen in the other two data sets.

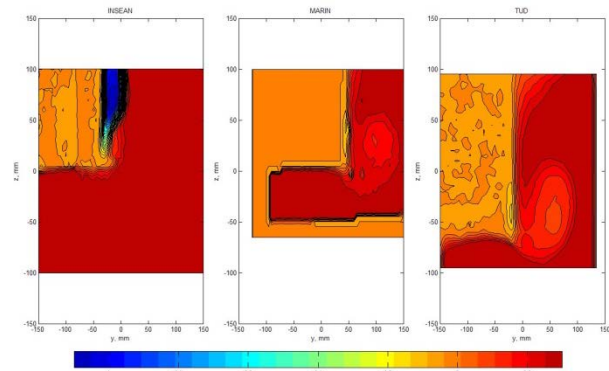

Figure 14:  $U$  velocity contours at the P1 plane. The order of images (from left to right) is INSEAN, MARIN and TUD.

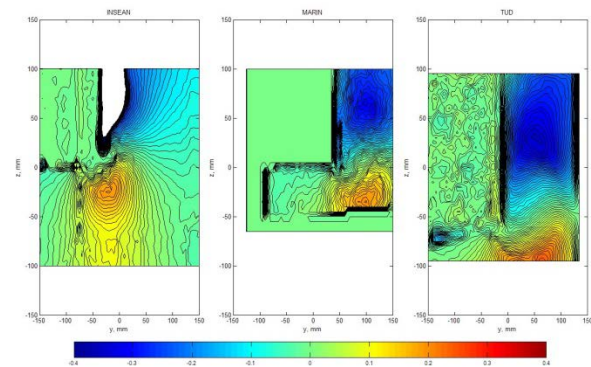

Figure 15:  $V$  velocity contours at the P1 plane. The order of images (from left to right) is INSEAN, MARIN and TUD.

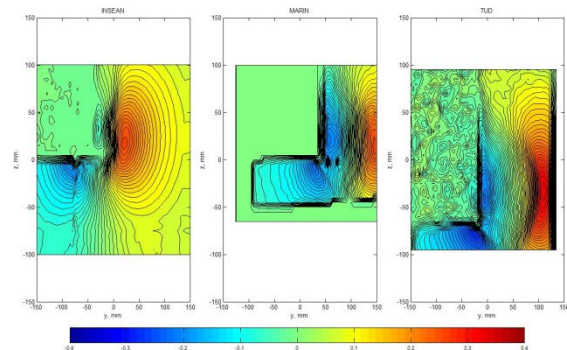

Figure 16:  $W$  velocity contours at the P1 plane. The order of images (from left to right) is INSEAN, MARIN and TUD.

The second in-plane velocity measurement,  $W$  (normal to the free surface, Figure 13), also shows a similar consistency in values measured

in the three data sets, but here there is a difference in the overall flow structure. Again, the INSEAN data seems to be affected the most, and does indicate a slightly different flow structure near the flat plate region.

The mean velocity fields,  $U$ ,  $V$ , and  $W$  at the P2 measurement plane are shown in Figures 17, 18, and 19 respectively. The results show that at least qualitatively, the results are similar between all the different measurements. The figures all show the presence of the tip vortex in the  $U$  velocity contours. The  $V$ , and  $W$  velocity contours are very similar in their distribution and values between the three measurements.

The results of the mean flow field for the PIV data show that in general, the results obtained from a PIV measurement are consistent qualitatively. The overall flow structure is similar in all the cases, with any differences attributed to a fundamental change in the laboratory or measurement technique. However, quantitatively, there still seems to be some variations in the values being obtained.

Analysis and comparisons of the mean flow fields between three different institutions revealed that the PIV technique is fairly robust and reliable when working under ideal conditions. Despite the fact that the same model was used in three different facilities, there were some differences in the flow field, primarily with respect to the location of various flow features. Each test case had a different PIV configuration and post-processing routines, and so some differences can be expected. By having access to a database of benchmark data, institutions will thus be able to evaluate their own systems and procedures in a simple and confident manner.

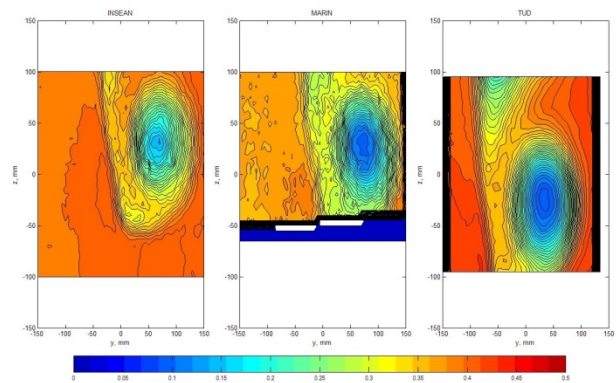

Figure 17:  $U$  velocity contours at the P2 plane. The order of images (from left to right) is INSEAN, MARIN and TUD.

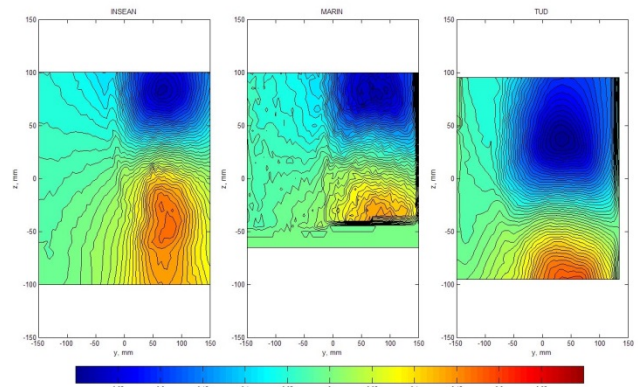

Figure 18:  $V$  velocity contours at the P2 plane. The order of images (from left to right) is INSEAN, MARIN and TUD.

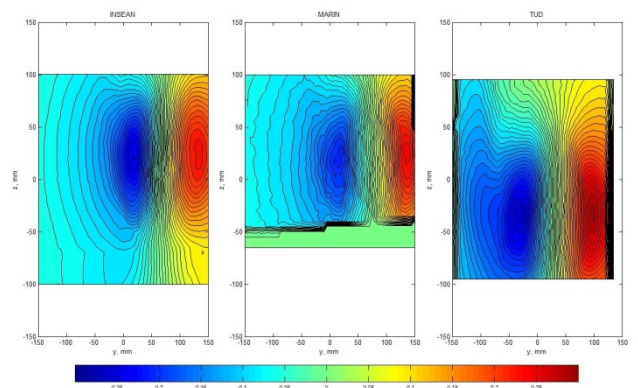

Figure 19:  $W$  velocity contours at the P2 plane. The order of images (from left to right) is INSEAN, MARIN and TUD.

## 5. ORGANIZATION

Benchmark data are stored in a dedicated repository at CNR INSEAN that voluntarily coordinates and supervises the benchmark test.

Coordination includes benchmark data collection and storage, quality check as well as repository management and care.

The repository is accessible by registration or log in to any ITTC participant organization that uploads or has already uploaded its database.



Figure 20: Repository organization.

The repository is structured into three levels as reported in Figure 20, namely:

- Level 1.** Level 1 involves two folders containing the data relative to the 2C-PIV benchmark and to the Stereo-PIV benchmark respectively;
- Level 2.** Each of the macro folders of level 1 consists of a number of sub-folders of level 2, each relative to the benchmark data uploaded by a certain user.

- Level 3.** Each folder of level 2 is structured into 4 sub-folders of level 3, as follows:

- Raw images:** this folder contains  $N_{i,k}$  image pairs in TIFF uncompressed or BMP format ( $N_{i,k}$  is the number of images stored by the  $i$ -th participant organization relative to the  $k$ -th benchmark, with  $k=2C$ -benchmark, SPIV-benchmark). In the Stereo-PIV benchmark this folder is organized in two sub-folders containing the  $N_{i,k}$  raw images relative to camera 1 and camera 2 respectively.
- Calibration images:** this folder contains the calibration images in TIFF uncompressed or BMP format. In the Stereo-PIV benchmark this folder is organized in two sub-folders containing the calibration images relative to camera 1 and camera 2 respectively.
- Vector fields:** this sub-folder contains  $N_{i,k}$  vector fields. In the Stereo-PIV benchmark this folder is organized in three sub-folders containing the  $N_{i,k}$  vector fields relative to camera 1 and to camera 2 (2C-fields) and to the reconstructed vector field (3C-field), after stereo reconstruction. Data are provided in ASCII according to the format reported in Table 2.
- File info:** this file contains all the info provided by the participant organization through the questionnaire (see Appendix A)

Instructions for how to access the repository are reported in Appendix C.

2C-fields	X	mm
	Y	mm
	Z	mm
	U	m/s
	V	m/s
3C-fields	X	mm
	Y	mm
	Z	mm
	U	m/s
	V	m/s
	W	m/s

Table 2 Data format for vector fields.

	<b>ITTC – Recommended Procedures and Guidelines</b>		<b>7.5-01 -03-04</b> Page 12 of 18	
	<b>Benchmark for PIV(2C) and SPIV(3C) setups</b>		<table border="1" style="width: 100%;"> <tr> <td style="width: 50%;">Effective Date 2017</td> <td style="width: 50%;">Revision 01</td> </tr> </table>	Effective Date 2017
Effective Date 2017	Revision 01			

## 6. REFERENCES

Hudy, L. M. and Naguib, A. M, 2003, “Wall-Pressure-Array Measurements Beneath a Separating/Reattaching Flow Region,” Phys. Fluids, Vol. 15, No. 3, pp. 706-717.

Muthanna et al, 2010, " PIV Operation in Hydrodynamic Facilities, a Flat Plate Benchmark test comparing PIV systems at different facilities", 15th Int Symp on Applications of Laser Techniques to Fluid Mechanics, Lisbon, Portugal, 05-08 July, 2010.

## Appendix A : QUESTIONNAIRE

### 1) Personal information

- 1.1 First name and family name
- 1.2 Email
- 1.3 Organization
- 1.4 How long is your experience with PIV?

### 2) Background of your organization

- 2.1 Commercial
- 2.2 Military
- 2.3 University
- 2.4 Other (please specify)

### 3) Benchmark and experiment information

#### 3.1 Benchmark type

- i. Splitter plate with a fence (2C-PIV benchmark)
- ii. Surface piercing flat plate at incidence (SPIV benchmark)

#### 3.2 Facility

- i. Hydrodynamic channel
- ii. Towing tank
- iii. Rotating arm
- iv. Flume
- v. Other (please specify)

#### 3.3 Test case description

3.3.1 Splitter plate with a fence (only for 2C-PIV benchmark):

- i. Material (e.g. aluminum, composite, Perspex)
- ii. Dimensions (please refer to Guideline 7.5-01-03-04):
  - H (mm)
  - $h_f$  (mm)
  - $\alpha_b$  (deg)
  - Splitter plate length (mm)
  - Splitter plate height (mm)
  - Splitter plate thickness (mm)
- iii. Surface treatment and paint (please specify if any)
- iv. Is the geometry compliant with specifications given in the Guideline 7.5-01-03-04? If not, please specify.

3.3.2 Surface piercing flat plate at incidence (only for SPIV benchmark):

- i. Material (e.g. aluminum, composite, Perspex)
- ii. Dimensions (please refer to the Guideline 7.5-01-03-04):
  - plate length (mm)
  - plate height (mm)
  - plate thickness (mm)
  - Leading edge radius (mm)
  - Trailing edge radius (mm)
  - plate incidence angle  $\alpha$  (deg)
- iii. Surface treatment and paint (please specify if any)
- iv. Is the geometry compliant with specifications given in the Guideline 7.5-01-03-04? If not, please specify.

#### 3.4 Optical lay out (only for SPIV benchmark)

With reference to the cases reported in Figure 8 of the ITTC Guideline 7.5-02-01-04, specify:

- i. Camera and laser configuration (among cases from a) to g))
- ii.  $\alpha$  (deg) ( $\alpha$  = angle between cameras)
- iii.  $\beta$  (deg) ( $\beta$  = angle between light sheet and nearest camera)

#### 3.5 PIV/SPIV hardware details

3.5.1 PIV/SPIV system type:

- i. Fully underwater
- ii. Fully dry
- iii. Partically underwater (please describe)
- iv. Did you use water filled prisms in front of cameras (reply only for fully dry or partially underwater systems)?
- v. Did you use Sheimpflug adapters (only for SPIV benchmark)?

3.5.2 Laser:

- i. Did you use a commercial or a custom model?
- ii. If a commercial laser is used, please specify:
  - Manufacturer
  - Model No
  - Laser Type
  - Power
  - Max Pulse Rate
  - Wavelength

3.5.3 Camera/cameras:

- i. Did you use a commercial or a custom model?

	<b>ITTC – Recommended Procedures and Guidelines</b>	<b>7.5–01 -03-04</b> Page 14 of 18	
	<b>Benchmark for PIV(2C) and SPIV(3C) setups</b>	Effective Date 2017	Revision 01

- ii. If a commercial laser is used, please specify:
  - Manufacturer
  - Model No
  - Sensor Type (e.g. CCD, CMOS)
  - No of bits
  - Resolution
  - Max Frame Rate

3.5.4 Lens configuration: please specify lens set up for light sheet generation among the following options:

- i. Only cylindrical (please specify the focal length)
- ii. Cylindrical + spherical (please specify the focal length for both lenses)
- iii. Other (please specify)

3.5.5 Seeding:

- i. See particle material (e.g. hollow glass spheres)
- ii. Size ( $\mu\text{m}$ )
- iii. Density ( $\text{kg}/\text{m}^3$ )
- iv. Supplier (if known)
- v. Seeding delivery (please describe)

### 3.6 Field of view

With reference to Appendix B of the ITTC Guideline 7.5-02-01-04, please specify:

- i. Position/positions of the measurement plane/planes (referred to the out of plane dimension in mm)
- ii. Field of view size (approximatively) (W x H in mm)

### 3.7 Measurement issues

3.7.2 Acquisition parameters:

- i. Timing of the two laser pulses  $\Delta t$  ( $\mu\text{s}$ )
- ii. Maximum displacement (pixel) (approximatively)
- iii. Acquisition frequency (Hz)

3.7.3 Particle density in the interrogation window (IW), please select among the following cases:

- i.  $< 7$  particles
- ii.  $7 \leq \text{particles} \leq 15$
- iii. particles  $> 15$

### 3.8 2C-PIV/SPIV software details

3.8.1 Please specify the software you have used:

- i. Commercial software (please specify Supplier, Software name and release)
- ii. Custom software (please specify)

3.8.2 Did you apply image pre-processing?

3.8.3 If yes, please describe the type of adopted image pre-processing (e.g. masking, minimum grey scale subtraction etc.) and the pre-processing parameters (e.g. subtraction of the mean grey scale levels, subtraction of 70% of the mean grey scale levels, etc.)

3.8.4 Image Correlation approach, please specify one or more cases in the following list:

- i. Image cross correlation (no offset deformation and no window deformation). Please specify size (px) and overlapping (in %) of the IW.
- ii. Offset correlation, please specify:
  - No of iterations
  - Size of the interrogation windows in the first iteration (px)
  - Size of the interrogation windows in the final iteration (px)
  - IW final overlapping (in %)
- iii. Window deformation (please describe)
- iv. Other

3.8.5 Please describe the adopted correlation type between the following cases:

- Direct correlation
- FFT

3.8.6 Did you apply vector validation and replacement criteria? If yes, please specify the adopted criteria and parameters.

### 3.9 2C-PIV/SPIV calibration

3.9.1 2D-PIV calibration (only for 2C-PIV benchmark):

- i. Target type (measuring ruler, etc.)
- ii. Magnification factor (px/mm)
- iii. Note (please provide any further information on the adopted calibration procedure)

3.9.2 SPIV calibration (only for 2C-PIV benchmark):

- i. Commercial or custom target (please specify Manufacturer and model No. if commercial)?
- ii. Target type (single plane plate, multi plane plate etc.)
- iii. Target size:
  - Length (mm)
  - Height (mm)
  - Thickness (mm)
- iv. Marker type (e.g. dot, cross, etc.)
- v. Marker size (mm)

	<b>ITTC – Recommended Procedures and Guidelines</b>		<b>7.5-01 -03-04</b> Page 15 of 18
	<b>Benchmark for PIV(2C) and SPIV(3C) setups</b>		Effective Date 2017

- |   |   |
|---|---|
| <ul style="list-style-type: none"> <li>vi. Final vector grid spacing (mm or px)</li> <li>vii. Note (please provide any further information on the adopted calibration procedure)</li> </ul> | <ul style="list-style-type: none"> <li>3.10.1 Set up times (hours)</li> <li>3.10.2 Calibration times (hours)</li> <li>3.10.3 Image acquisition times (hours)</li> <li>3.10.4 Image processing time (hours)</li> </ul> |
|---|---|

**3.10 Set up, acquisition and processing times**

**Appendix B BENCHMARK PERFORMANCE INSTRUCTIONS**

**1) 2C-PIV Benchmark**

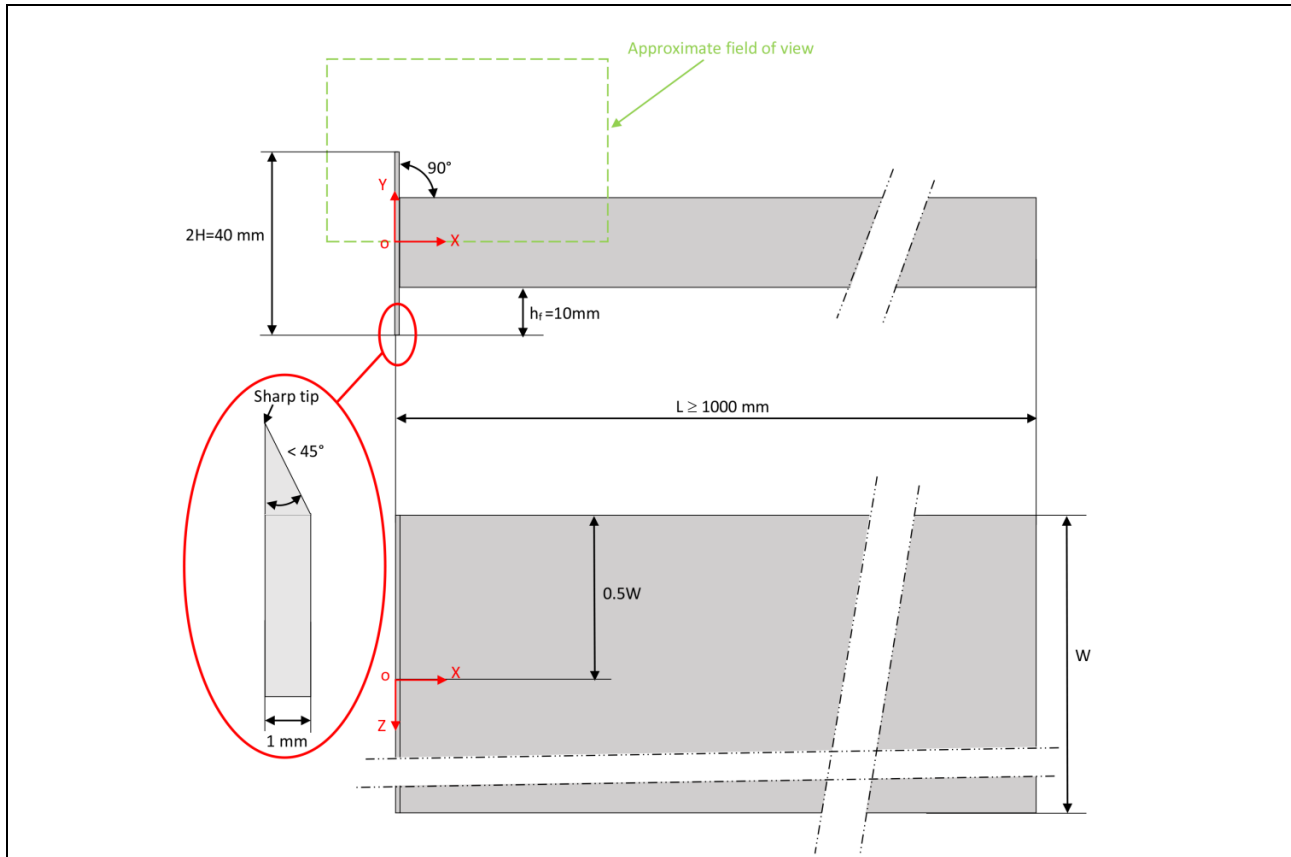

<b>Geometry and material</b>	$2H$	40mm
	$h_f$	10 mm
	$L$	$>100 h_f$
	$W$	Large enough to avoid 3d effect in the measurement section
	Material	Aluminium or steel
<b>Field of view and plane position</b>	Out of plane position of measurement plane	$Z=0$
	Recommended field of view (minimum size)	$-1.5 h_f < X < 4.5 h_f$ $0.5 h_f < Y < 4.5 h_f$
<b>Measurement conditions</b>	$U_\infty$	5m/s (low speed) or 10 m/s (high speed)
<b>PIV image format</b>	TIFF or BMP	
<b>Vector field format</b>	X (mm), Y (mm), Z (mm), U (m/s), V (m/s)	

**2) Stereo-PIV Benchmark**

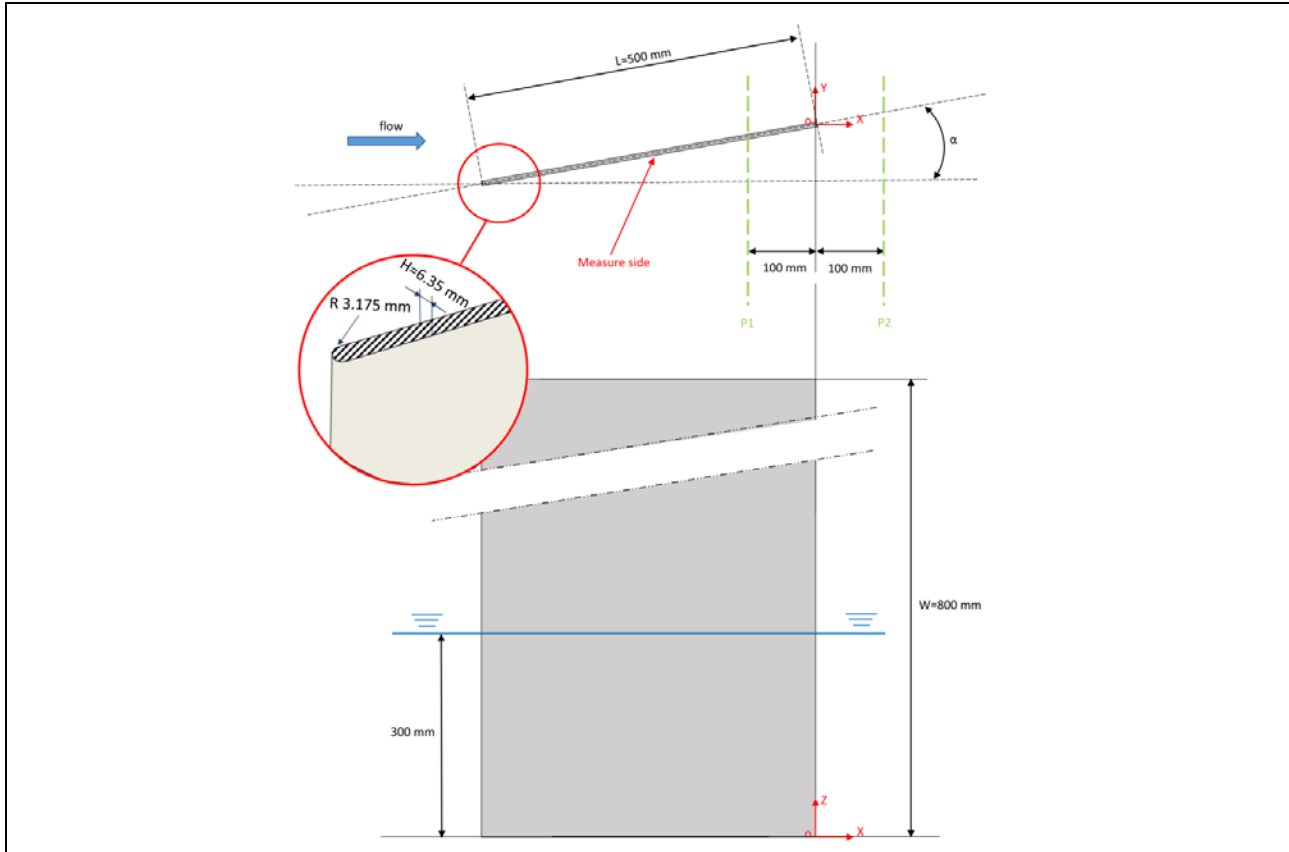

<b>Geometry and material</b>	L	500 mm	
	W	800 mm	
	H	6.35 mm	
	Material	steel	
<b>Field of view and plane position</b>	Plane P1	Out of plane position	$x = -100$ mm
		Recommended field of view (approximately)	$-150 \text{ mm} < Y < 150 \text{ mm}$ $-100 \text{ mm} < Z < 100 \text{ mm}$
	Plane P2	Out of plane position	$x = 100$ mm
		Recommended field of view (approximately)	$-150 \text{ mm} < Y < 150 \text{ mm}$ $-100 \text{ mm} < Z < 100 \text{ mm}$
<b>Measurement conditions</b>	$U_{\infty}$	0.4 m/s (towing tank) or 2 m/s (free surface channel)	
	$\alpha$	20 deg (towing tank) or 5 deg (free surface channel)	
<b>PIV image format</b>	TIFF or BMP		
<b>Vector field format</b>	X (mm), Y (mm), Z (mm), U (m/s), V (m/s), W(m/s)		

	<b>ITTC – Recommended Procedures and Guidelines</b>	<b>7.5–01 -03–04</b> Page 18 of 18	
	<b>Benchmark for PIV(2C) and SPIV(3C) setups</b>	Effective Date 2016	Revision 01

## Appendix C : REPOSITORY ACCESS

The Repository is accessible at this URL:  
<http://www.ittc-benchmark.cnr.it>.

Repository access is regulated as follows:

- At the first access, each participant must complete a registration procedure, as shown in Figure 21. At the end of the registration procedure, the user receives login credential (i.e. username and password) and is enabled to fully access to the database.
- The registration procedure involves the following steps (Figure 21):
  1. The user fills an on-line questionnaire with personal information (i.e. name, affiliation, etc.) and details about the database to be uploaded (e.g. benchmark type, experimental rig, image calibration and processing procedure, etc.). The questionnaire, which is reported in Appendix A, aims at proving any other user with all the relevant information about the experimental campaign;
  2. The user is enabled to upload the database in a temporary folder of level 2, once the questionnaire has been successfully verified by the coordinator. Any wrong or incomplete part of the questionnaire is notified to the used by email and must be fixed by a deadline.
  3. Data must be uploaded according to the structure described in Figure 20.
  4. The coordinator checks for the compliance of the database with format and content specifics:
    - If the database is compliant, the user receives definitive access credentials (username and password) and is enabled to fully access to the database. The temporary folder is turned into definitive.
    - If the database is non-compliant, non-compliances are notified to the used by email and must be fixed by a deadline, the temporary folder and the questionnaire will be deleted otherwise.

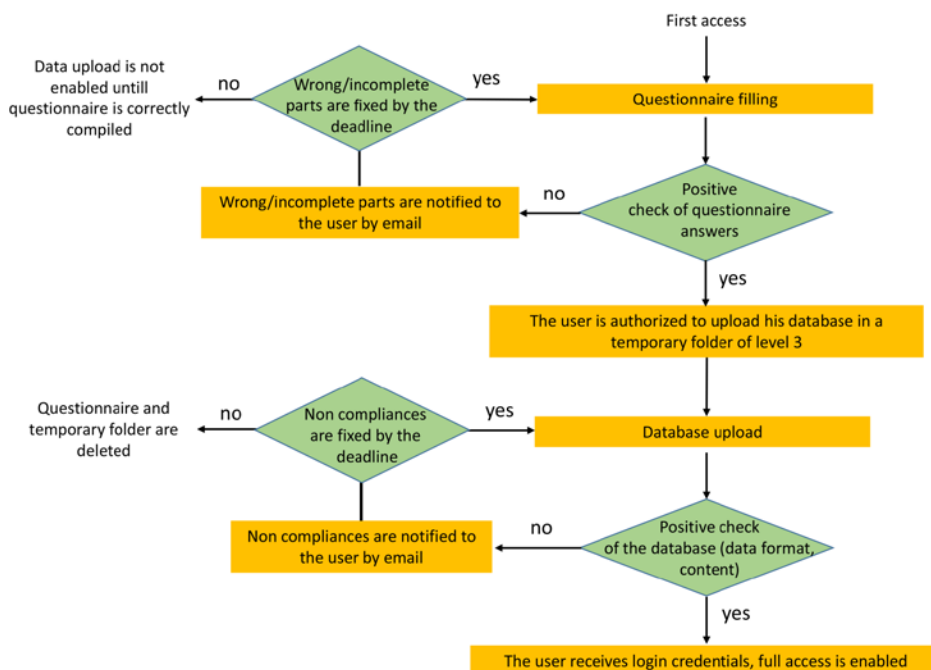

Figure 21: Repository access procedure.