

CIRCULATING WATER CHANNELS AND CAVITATION TUNNELS

AKISHIMA LABORATORY, JAPAN
 MITSUI ENGINEERING & SHIPBUILDING CO., LTD.
 1-50, TSUTSUJIGAOKA 1-CHOME, AKISHIMA CITY, TOKYO 196, PHONE: 0425-45-3111

CAVITATION TUNNEL (1984)

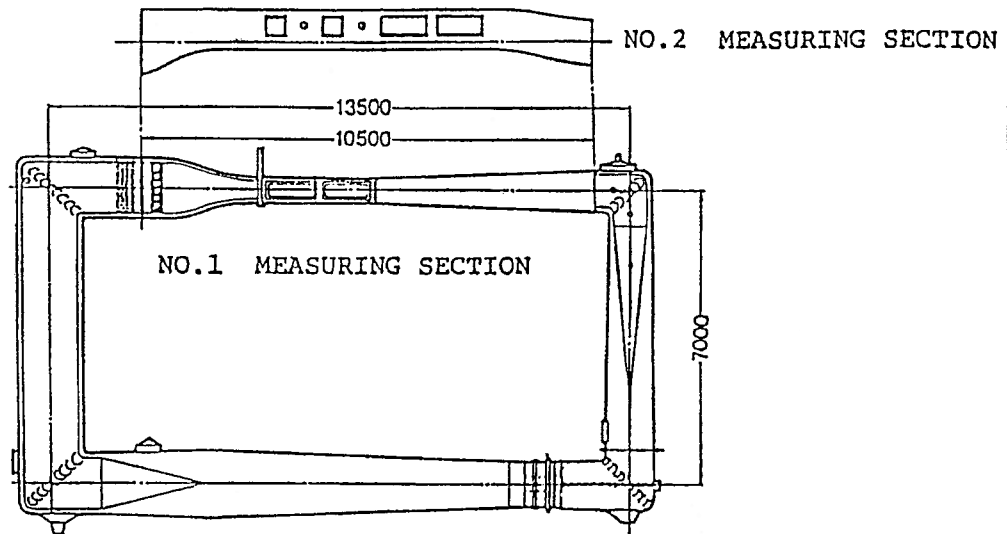

DESCRIPTION OF FACILITY: Vertical closed recirculation
 No.1 measuring section: 600mm x 600mm
 No.2 measuring section: 850mm x 1,200mm

TYPE OF DRIVE SYSTEM: 4-bladed axial flow impeller with
 thyristor leonard control

TOTAL MOTOR POWER: 120 kW, +380 ~ -190 rpm

WORKING SECTION MAX. VELOCITY: No. 1 measuring section 14 m/s
 No. 2 measuring section 5 m/s

MAX. & MIN. ABS. PRESSURES: 200 kPa, 10 kPa

CAVITATION NUMBER: $\sigma > 0.2$

INSTRUMENTATION: No.1 propeller dynamometer
 strain gauge/downstream-type, positions and shaft rake
 angle controllable
 max. thrust ± 1961 N, max. torque ± 98 Nm

No.2 propeller dynamometer
 strain gauge/inboard-type
 max. thrust ± 1177 N, max. torque ± 39 Nm

Traverse system for wake survey
 Underwater noise measuring system
 Laser doppler velocimeter
 Mini. computer system
 for the control of test condition, data processing and
 measuring devices

PROPELLER SIZE: Standard 250 mm diameter

DUMMY MODEL SIZE: Standard length 3 m

TEST PERFORMED: Cavitation tests in uniform and non-uniform flow.
 Measurements of propeller forces, velocity field, hull
 surface pressure, underwater noise and gas content.

PUBLISHED DESCRIPTION: published in Mitsui Tech. Review in 1985